

CL408/412 Quick Guide

Table of Contents

What You Get	2
Controls and Indicators	3
Operator Panel	3
LED Indicators	3
Adjustments	3
Keys	4
Rear Panel Connections	4
Initial Setup	5
Connecting the Printer	5
Printing a Test Label	6
Configuring the Printer	7
Computer Connections	7
CL408/412 Software and Drivers	9
Label Wizard SE	9
Windows Drivers	10
What to do if it will not print	10
CL408/412 Specifications	14
Media and Supplies	15
Options	15

This Quick Guide was prepared to get you up and running quickly. It will enable you to get your new SATO CL408/412 installed and printing with a minimum of effort. However, it is recommended that you familiarize yourself with the contents of the CL408/412 Operator and Technical Reference Manual for detailed descriptions so you will be able to properly use the printer to its full potential.

CL408/412 Quick Guide

What You Get

The CL408/412 Thermal Transfer printer comes packed in a protective carton. Included in the carton are the following items:

- CL408/412 Printer
- Quick Guide
- Operator and Technical Reference Manual
- Head Cleaning Sheet
- Sample Ribbons and Ribbon Take-Up Core
- Power Cable
- Test Printout Labels
- Label Wizard SE CD-ROM



After taking the CL408/412 from the carton and removing the protective plastic cover, it is ready for installation.

CL408/412 Quick Guide

Controls and Indicators

Operator Panel



LED Indicators

Status: Dark when Off Line
 Green when printer is On Line.
 Red when an error condition exists.
 Flashing green when printer is imaging data.

LCD Display: Illuminated when power is applied.

Adjustments (controls behind front panel)

Print: Adjusts print darkness.

Offset: Adjusts amount of back/forward feed for dispense/cut/tear-off position.

Pitch: Adjusts home position of the label +/- 3.75 mm. Affects stop position of label, print position and dispense/cut position.

DSW2-3: Sets printer configuration

CL408/412 Quick Guide

Keys

- Line:** Toggles printer between On Line and Off Line mode. During printing it will pause the printer during a print job.
- Feed:** When Off Line, will feed one blank label. When On Line will print another copy of the last printed label.
- Display Panel:** 2-Line x 16 character LCD for setting operational parameters and displaying error conditions.
- DSW2-3:** DIP switches for configuring printer operation.
- Power:** Turns printer On and Off.

Rear Panel Connections

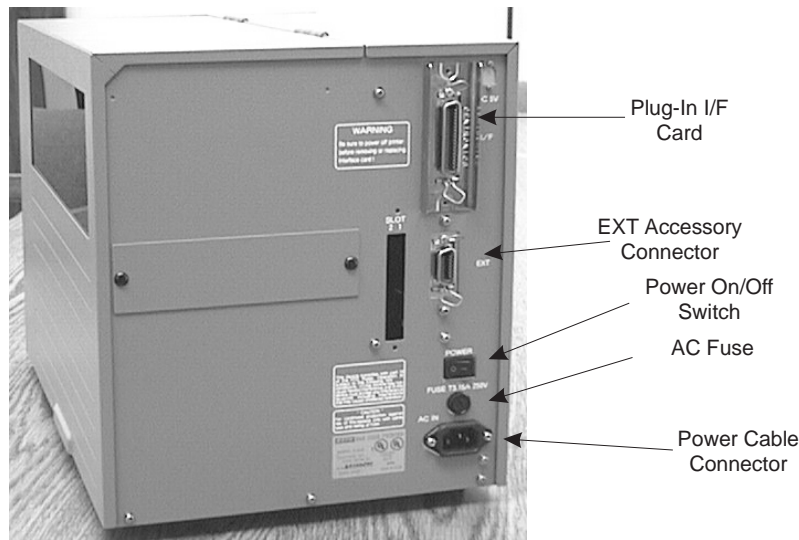

- AC Input:** 115V 50/60 Hz connector. Use the cable supplied.
- AC Fuse:** Input power protection. Type 3A/250V.
- Plug-In Interface:** Plug-In Interface Card. Type specified at time of order. See Operator and Technical Reference Manual for descriptions.
- EXT:** External signal connector, Amp 57-60140.

CL408/412 Quick Guide

Initial Set-Up

Connecting the Printer

1. Locate a suitable spot for the printer. It should be within 6 ft. of the host if using a Parallel interface or within 50 ft. if using an RS232 interface. For other types of Plug-In interface cards, see the Operator and Technical Reference Manual. Make sure there is adequate room above and to the right of the printer for the label access door to swing open.
2. Plug the AC cable provided into the back of the printer and connect to a suitable 115VAC outlet.
3. Open the print head and load the ribbon using the ribbon routing guide located on the inside of the top cover. Be sure to position the ribbon roll correctly on the Ribbon Supply Spindle and place the spare take-up core on the Take-Up Spindle. Tape the free end of the ribbon to the take-up core so that it will take-up when rotating in a counter clockwise direction.
4. Place the label roll on the Label Supply Spindle and push the green Label Roll Retainer on the spindle until it pushes the label roll all the way to the inside of the printer. The labels should come off the bottom of the roll (labels wound face-in on the roll).
5. Route the labels as indicated by the label routing diagram on the inside of the top cover. The labels should go under the plastic guide, through the Label Sensor Assembly, under the print head and out the front of the printer. Position the Label Edge Guide toward the inside of the printer until it barely contacts the outside edge of the labels.
6. Close the Print Head Latch and then the side access door last.
7. Select the proper label sensing method using the front panel DIP switches. The DIP switch function chart is located on the inside of the front cover. The printer comes from the factory set for label gap detection (DSW2-2, DSW3-3 both OFF). Note that the OFF position for the DSW switches is down and the ON position up.
8. Apply power by placing the front panel Power switch in the "1" position.
9. The Power and On-Line LEDs should be illuminated and ONLINE should be displayed on the LCD.
10. Press the LINE key once. The On Line LED should go out and OFFLINE should be displayed on the LCD.
11. Press the FEED key once. The printer should feed out one label and stop.

CL408/412 Quick Guide

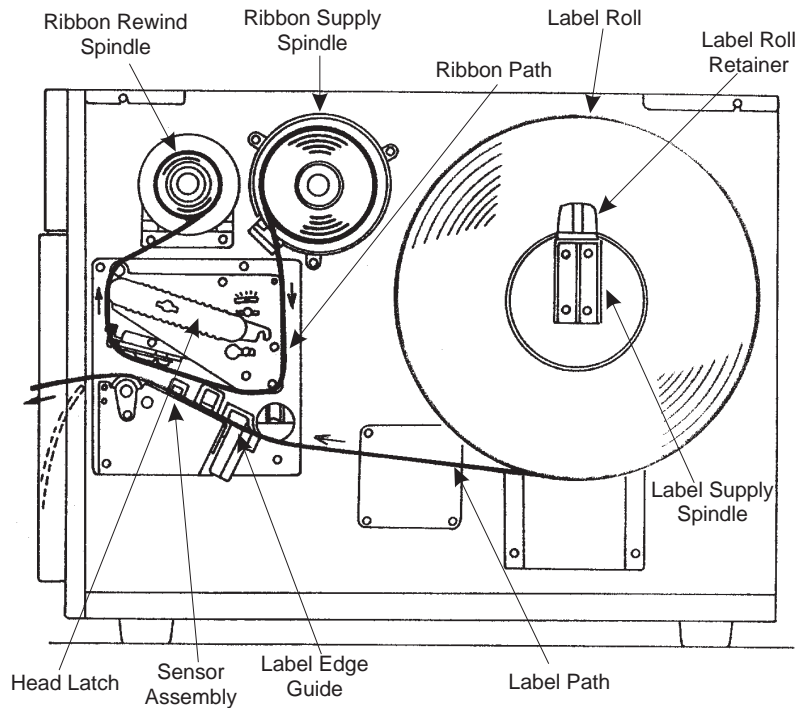

12. If the printer feeds 20" of blank labels and stops with a "SENSOR ERROR" on the LCD screen, check to make sure the labels are properly routed through the label sensor and not over the top of it.
13. Turn AC power off by placing the POWER switch in the "0" position.

Printing a Test Label

After labels and ribbon are loaded into the printer, a test label can be printed using the Front Panel Controls.

1. Apply power to the printer while simultaneously pressing the FEED key.
2. The printer will beep once and display a "USER TEST PRINT, Small Large" on the LCD screen.
3. Large is the default selection. If you have labels loaded that are at least 4" wide, use the Large selection. If your labels are smaller than 4"



CL408/412 Quick Guide

wide, press the LINE key to toggle the underline cursor to the Small selection. If Large was selected, pressing the FEED key will print a test label. If Small was selected, pressing the FEED key will display the Print Size message. This screen allows you to adjust the width of the test printout from a minimum of 1.6" (04 cm) to a maximum of 4" (10 cm) by using the LINE key to increment the displayed size. Once the correct label size is entered, pressing the FEED key will initiate a small test label print cycle.

4. The printer will continue to print test labels until the FEED key is pressed, placing the printer in the PAUSE mode. Pressing the FEED key again will continue the test label printing cycle.
5. To stop printing test labels, pause the printer by pressing the FEED key and then turn power off. Turning power back on will place the printer in the normal On-Line mode where it is waiting for print data.

Configuring the Printer

The CL408/412 comes from the factory with all Front Panel and Interface DSW switches in the Off (or down) position. DSW-1 is located on the Serial RS232 Plug-In Interface card. This configures the printer for the following operation:

- Thermal transfer printing.
- If an RS232 Serial Interface is installed, it will be set for 9600 BPS, no parity, 8 data bits, 1 stop bit and Ready/Busy Flow Control. There are no interface settings for the Parallel or USB interfaces.
- Label sensing set to detect label gaps.
- Continuous label printing.

Other features can be enabled with different DSW switch combinations. The function of each DSW switch is listed on a chart on the inside of the front cover. A more detailed description is provided *Section 2 of the Operator and Technical Reference Manual* shipped with the printer. When changing configuration via the DSW switches, the power to the printer must be cycled before the new settings become activated.

Computer Connections

The CL408/412 comes with Plug-In Interface card with the appropriate connector. The type of Plug-In Interface card desired is specified at the time of order and is shipped separately with the printer. It must be installed in the printer before the computer connection is made.

CL408/412 Quick Guide

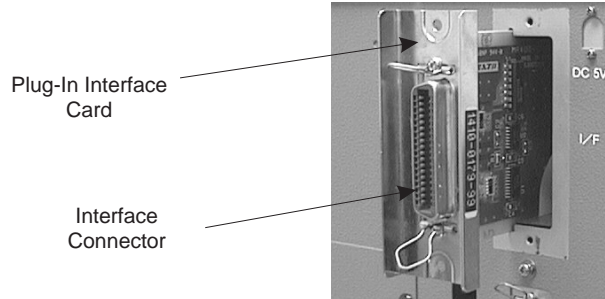

To complete the installation you will need the appropriate interface cable to connect the printer to the output port of the host computer. These can be purchased locally or from your SATO supplier. If you need additional information on interface types, connector types or cabling pin-outs, please refer to *Section 5 of the Operator Manual*.

The most common interface connections are Parallel and RS232 Serial.

Parallel Interface

The Parallel interface connector is an AMP 57-40360 female 36 pin Centronics type.

Pin #	Description
1	Strobe
2-9	Data bits 0-7
10	Acknowledge
11	Busy
12	Out of Paper
13	+5VDC
17	Chassis Ground
31	Reset
32	+5VDC
16, 33 19-30	Signal Ground

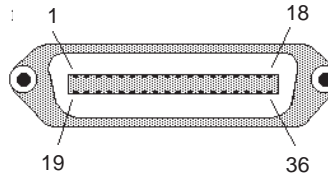

There are no DSW configuration switch settings required for the parallel interface.

CL408/412 Quick Guide

Serial Interface

Pin #	Description
1	Frame Ground
2	Transmit Data
3	Receive Data
4	Request-To-Send
5	Clear-To-Send
6	Data Set Ready
7	Signal Ground
20	Data Terminal Ready

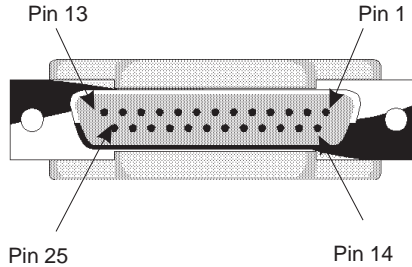

The RS232 Serial interface connector is a DB-25F. To correctly interface to a PC serial port requires a DB-25P/9P to DB-25F Null Modem Cable. The DSW1 configuration settings for the RS232 data format must match those of the host system. If they do not, the printer will beep when data is sent and display a FRAMING ERROR message on the display. If the Baud Rate selected by DSW1-5 and DSW1-6 does not match that of the host, the printer will ignore any data sent. The serial baud rate and word format settings can be changed on either the printer or the host to correct the condition, but they must match.

CL408/412 Software and Drivers

Label Wizard SE

A copy of Label Wizard SE is included on the CD-ROM shipped with each printer. Label Wizard SE is an evaluation copy of SATO's Label Wizard Design and Production software for Windows 3.1/95/98. It can be used with any SATO printer. The SE version is a fully functional label design software package but is limited to printing only one label at a time. It can be upgraded at any time to a full Label Wizard version, complete with sophisticated label production capabilities by purchasing an upgrade package from your SATO dealer. Any label design created in the SE version can be used in the upgraded package. The Label Wizard SE software is an excellent vehicle for experimenting with different label designs and demonstrating the features of SATO printers.

When loading the Label Wizard SE software on your PC, make sure that you also load the SATO Generic Printer Driver which is required for printing (this is not the same driver as the Windows drivers described below).

A complete set of Label Wizard documentations is provided on the CD-ROM.

CL408/412 Quick Guide

Windows Drivers

Windows drivers are also provided on the Label Wizard SE CD-ROM. They let you print labels from virtually any Windows application program. The driver is loaded like any other Windows printer driver. The various drivers for Windows 3.1, Windows 95/98 and Windows NT operating systems are located in the Win_dvr directory on the Label Wizard SE CD-ROM.

After the driver is installed, you can send data to the CL408/412 just like any other printer on your system: simply specify CL408 (or CL412) in the Print dialog box of your Windows application. Printer configuration is managed using the Advanced dialog box. To print bar codes, you must first define a bar code font using the Barcodes dialog box. Documentation describing how to load, configure and use the Windows driver is contained on the CD-ROM.

Windows drivers are very convenient for printing limited numbers of labels or simple production jobs. However, they can also be very inefficient in the way they transfer data. For example, if you choose a printer resident font, the printer responds very quickly. However, if you specify a Windows True-Type font, it is transmitted to the printer in a graphics format that results in large data transfers to the printer, slowing down the printer response time. It is always best to use a Label Design program that supports all of the features of the SATO printer being used, thereby increasing the efficiency of the operation and ensuring optimum response time.

What to do if the printer won't function

Printer won't go On-Line

- Is the Power LED on? Check the power cable and AC Fuse.
- There is an error condition. Make sure the Head Latch is closed.

Printer beeps and refuses to print

- This is usually caused by an incorrect data stream. Try placing the printer in the Hex Dump mode and printing a copy of the data being sent to the printer. Examine the incoming data a stream for incorrect command usage. Refer to the *Operator and Technical Reference Manual* for explanations of proper command usage.

Printer does not print when I send it data.

- Check the interface cable to make sure it is connected to the correct port on the PC.
- If you are using the serial interface, verify that the baud rate of the host matches that of the printer.

CL408/412 Quick Guide

- Some complex labels with large graphic images can take a long time to transmit to the printer (especially when using the serial interface) and image in the buffer before they can be printed. Have you allowed enough time for this process?
- The On-Line LED will blink while the printer is imaging a label in memory. If it is a very small label, the On-Line led will blink quickly one time. If it is a long label, it will blink for a correspondingly longer time.
- If the On-Line LED does not blink, place the printer in the Hex Dump mode and resend the data stream. A list of the received data characters will be printed out in hexadecimal format. See Section 2, Hex Dump Diagnostic Labels on page 35 of the *Operator and Technical Reference Manual* for information on how to place the printer in the hex dump mode. If the data cannot be printed in the Hex Dump mode, the printer is not receiving any data.
- Make sure your computer program is sending data to the correct printer. More than one printer can be assigned to the same port in the Windows Printer dialog box. Make sure the printer listed in the Print Setup window is the CL408/412. (Note: The correct printer driver to use for Label Wizard is labeled “SATO Generic”)

The printer feeds a label, but does not print anything

- Is the label wide enough? The first dot print position is on the outside edge of the print head and narrow labels are justified toward the inside of the printer. You may have to configure the printer with an Offset value to correctly position the image on the label. Refer to the *Operator and Technical Manual, Section 2* for instructions on how to do this.
- If you are printing in the direct thermal mode, make sure you are using direct thermal paper.
- If you are printing in the thermal transfer mode, check to make sure the ribbon is loaded properly with the ink (dull side) in contact with the media.

Poor quality printing

- If the print has sections missing, visually inspect the print head to make sure it is clean and has no physical damage. If foreign matter is observed, clean the head using a cotton swab and the Thermal Print Head and Platen Cleaner from the SATO cleaning kit.

CL408/412 Quick Guide

- If the print is too light, increase the heat setting using either software or the LCD panel. If the print is too dark and the bars in a bar code are fuzzy and run together, lower the heat setting. Fine adjustments can be made by adjusting the PRINT potentiometer on the front panel.
- If the print is too light, try varying the print speed using either the LCD panel or software commands.
- Is your ribbon/label combination compatible. Low quality paper labels may have a surface that is too rough for resin based ribbons to adhere. Wax based may not be able to adhere well to some synthetic label material.

LCD displays “SENSOR ERROR”

- Check to make sure the sensing method selected matches the media loaded. The CL408/412 comes from the factory set for detecting a label gap (DSW2-2 = On) and there must be a gap of at least 1/8" between labels. If Eye-Mark (a black line across the underside of the label) labels are used, DSW-2 must be On to enable the reflective sensor.
- If continuous media is being used without any type of registration, the sensor must be turned off (DSW3-3=ON). Otherwise, the printer will feed approximately 20" of paper and then give a “SENSOR ERROR” message.
- If the label gap or eye-mark registration bar does not extend across the width of the label, you may have to adjust the position of Label Sensor Assembly. See the *Operator and Technical Reference Manual, Section 2* for information on adjusting the Label Sensor Assembly.
- Make sure the labels are routed *through* the Label Sensor, not over the top of it.

LCD displays “FRAMING ERROR”

- Communication format between the printer and host must be synchronized when using the serial interface. The CL408/412 RS232 Serial Interface card comes from the factory set for no parity, 8 data bits, 1 stop bit (N,8,1) at 9600 bps and using a Ready/Busy data flow control handshake (DSW1-8 = Off). If the computer is sending data in a different format, the printer is not able to correctly interpret it and a FRAMING ERROR message will appear on the LCD screen.

CL408/412 Quick Guide

The printer is receiving data and seems to print, but the labels come out blank

- Check the ribbon to make sure the ink-side (the dull side) of the ribbon is in contact with the label. Other manufacturers may wind their ribbons differently. If they are loaded according to the diagram, it will place the ink-side of the ribbon up. If this happens, you should clean the ink from the print head before reloading the ribbon.

LCD displays a “PAPER END ERROR”

- Are the labels pushed all the way to the inside of the printer and held in position by the Label Edge Guide? The Paper Out switch is located near the inside edge of the label path. If it is not in contact with the media, a PAPER END ERROR results. Check to make sure a notch or hole in the label is not causing the Paper Out switch to give a false indication.

LCD displays a “RIBBON END ERROR”

- If the Ribbon Supply Spindle is not turning, a RIBBON END ERROR will be generated. Make sure the ribbon supply core is not oversize and spinning freely on the spindle.
- If the Darkness setting is too high, it can sometimes make the ribbon “stick” to the label. The resulting interruption in the ribbon movement can give a false RIBBON END signal.
- Are you printing on direct thermal paper but have not configured the printer for direct thermal printing with DSW2-1=On? In the direct thermal mode, the ribbon motion sensor is disabled since ribbons are not used for direct thermal printing.

CL408/412 Quick Guide

CL408/412 Specifications

The following is an abbreviated list of the CL408/412 specifications. For a complete listing, please refer to *Section 1 of the Operator and Technical Reference Manual*.

Model:	CL408/412
Print Method:	Thermal Transfer or Direct Thermal
Resolution:	203/300 dpi 8 dpmm/12dpmm
Max. Media Width:	5.0" 128 mm
Max. Print Width:	4.1" 104 mm
Max. Print Length:	14" 356 mm
with 2M Memory	49.2/32.8" 1249/833 mm
Max. Print Speed:	6 ips 150 mm/s
Physical Size:	10.7" W x 16.9" D x 12.6" H 271 mm W x 430 mm D x 321 mm H
Weight:	28.7 lbs. 19 kg
Max. Media Roll OD:	8.6" 218 mm
Label Sensing:	Eye-Mark, Gap, Notch or None
Min. Form Length:	0.24" 6 mm
Text Fonts:	13
Ribbon	1475 ft 450 m
Graphics:	PCX and SATO Hex/Binary
Bar Codes:	18 including 3 2-D bar codes
Rotation:	Text and bar codes can be rotated in four 90° increments
Power:	110/220 +/- 10%, 50/60 Hz, +/- 1%
Environmental:	Operating: 41° to 104° F (5° to 40° C) Storage: 0° to 104° F (-20° to 40° C) Relative Humidity: 25 to 85% non-con- densing

CL408/412 Quick Guide

Media and Supplies

The CL408/412 comes from the factory set up to operate with high quality TechnoTherm thermal transfer media and ribbons. Sample premium quality SATO Standard wax and Premier II wax/resin ribbons are shipped with the printer.

Other media and supplies may or may not give acceptable results in the CL408/412. It is likely that you will have to experiment with the heat and speed settings to obtain quality printing. Instructions for adjusting the heat and speed for optimum print quality can be found in the *Operator and Technical Reference Manual in Section 3*.

Options

Plug-In Interface

The CL408/412 uses Plug-In Interface cards for maximum flexibility. Currently available interfaces are Parallel, Serial RS232, Universal Serial Bus (USB) and 10BaseT Ethernet.

Label Dispenser

The CL408/412 Label Dispense Option is an internal mechanism that provides the ability to print labels in the “demand” mode. When it is installed, the printer dispenses one label at a time, peeling the backing from the label. The excess label backing is taken up on an internal rewind spindle.

Label Cutter

The CL408/412 Cutter Option is an internally mounted mechanism that will cut labels or tags as they exit from the printer.

PCMCIA Memory Expansion

The Memory Expansion option provides the connectors and interface for two PCMCIA Memory Cards. Each PCMCIA card slot will accept SRAM memory cards up to 2MB in size.

Calendar Option

The Calendar Option allows the date and time to be maintained in the local printer where it can be recalled for label printing. The Calendar Option is Y2K compliant and supports both standard and Julian dating.

CL408/412 Quick Guide

Label Rewinder

The Label Rewinder is an external mechanism that allows labels to be re-wound on a roll as they are being printed. The maximum roll capacity is 10".

Cleaning Kit

The cleaning kit contains a cleaning sheet, head cleaning solution, cotton-tipped cleaning swabs and cleaning towels for ensuring your CL408/412 is always capable of the highest quality printing.